



Roquetinho 115 Metal Parts



- Door and frame unit
- Secondary air channel
- Top plate and frame

See the description at roquetinho.eu/en

Veja a descrição em roquetinho.eu/pt

Zie de beschrijving op roquetinho.eu/nl

Feed and stub from tube 30 x 30 x 2 mm
 Hat of stub: 67 x 42 x 2 mm
 Plate: 158 x 48 x 4 mm
 Closing plate 60 x 30 x 2 mm

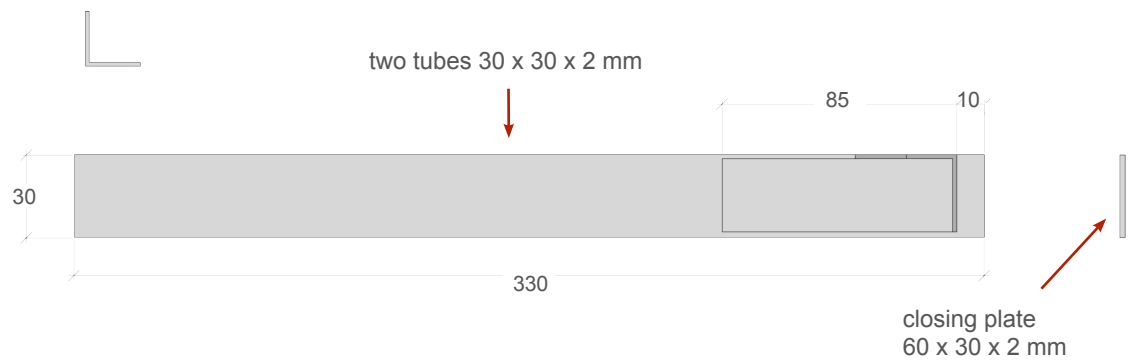
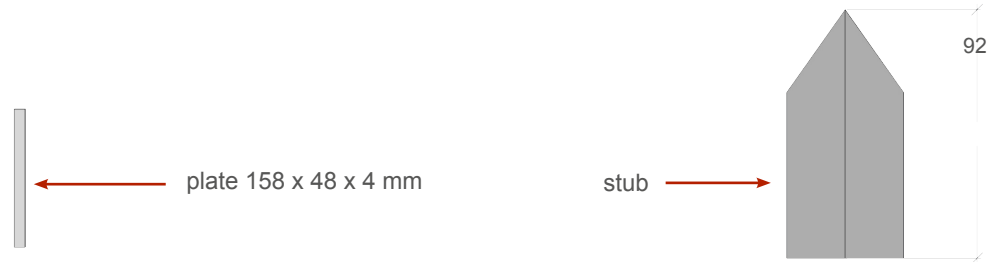
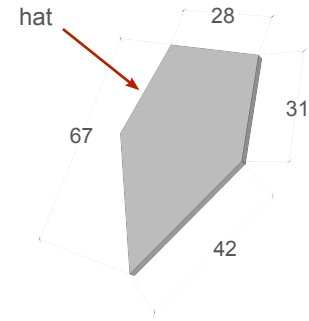
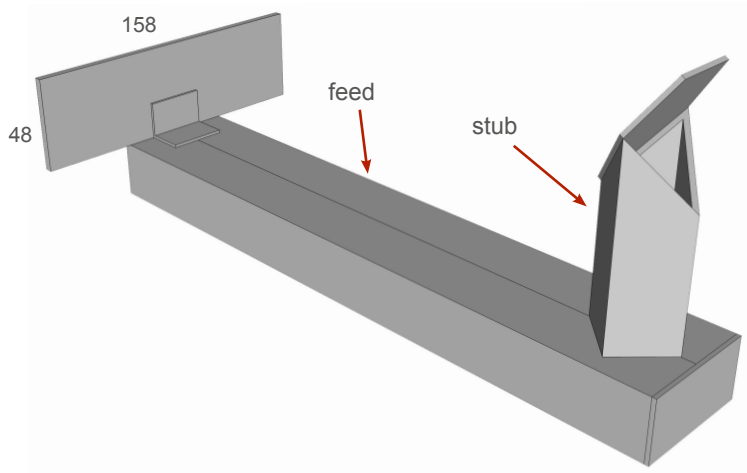
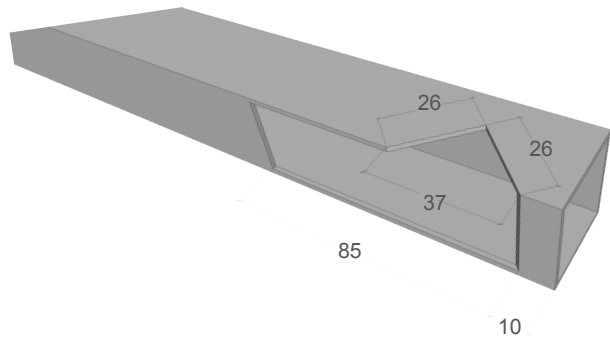

1. Secondary air channel (floorchannel)

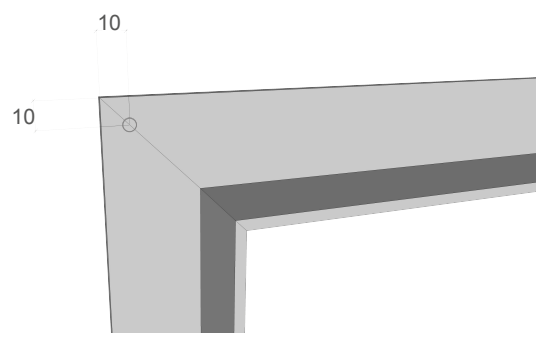
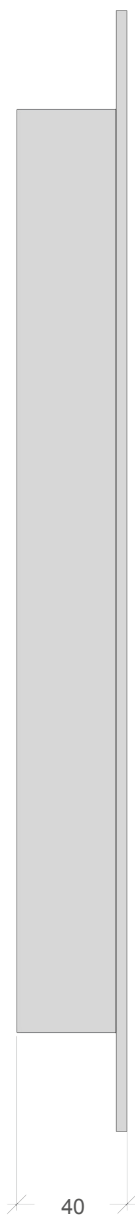
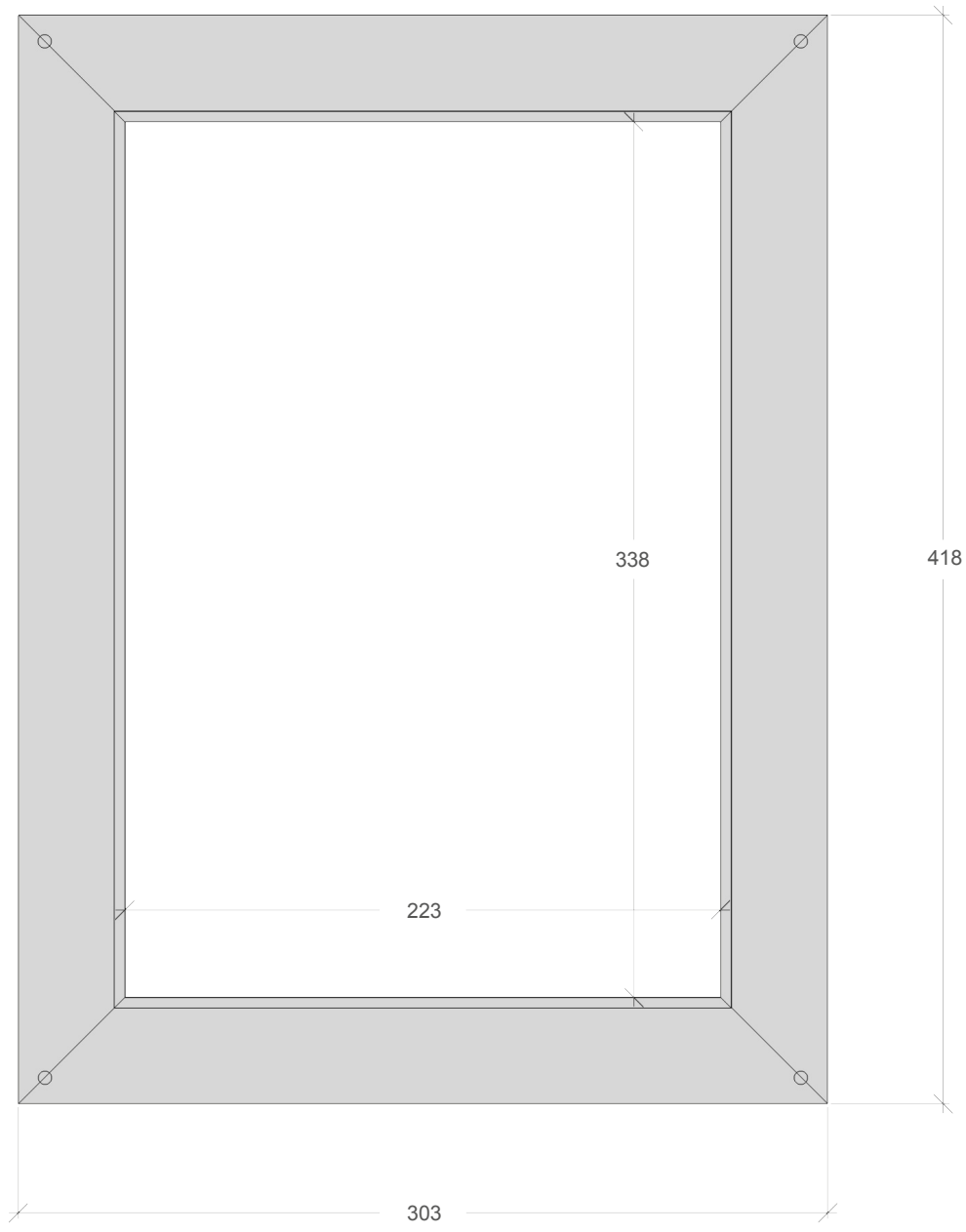

2. Frame dimensions and location of the holes
L-profile 40 x 40 x 4 mm

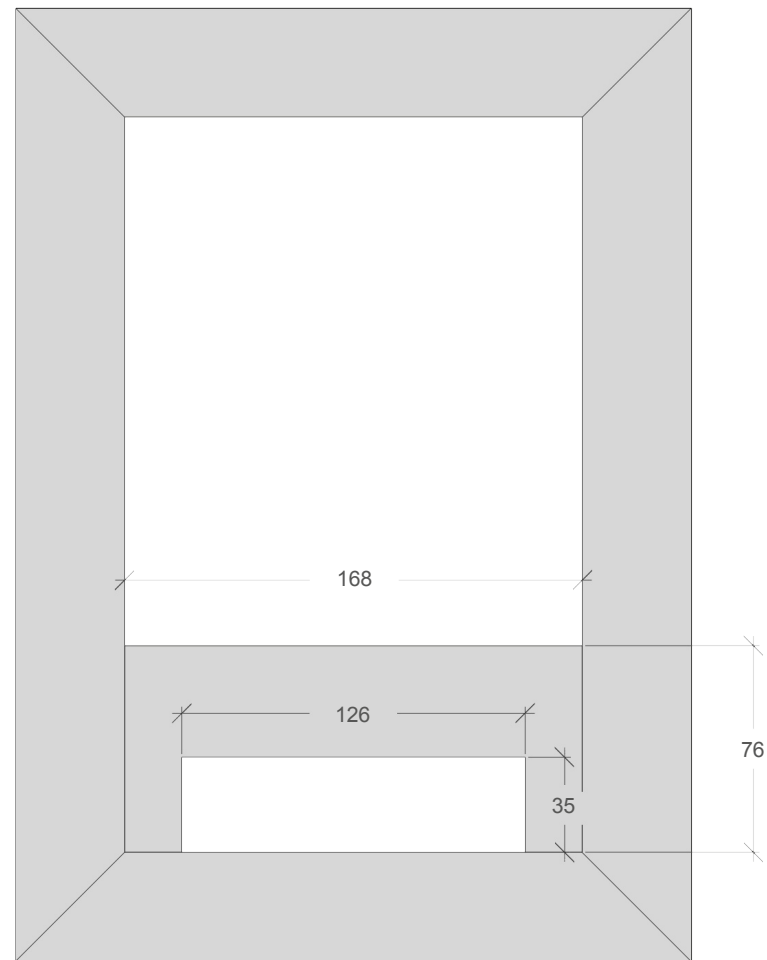
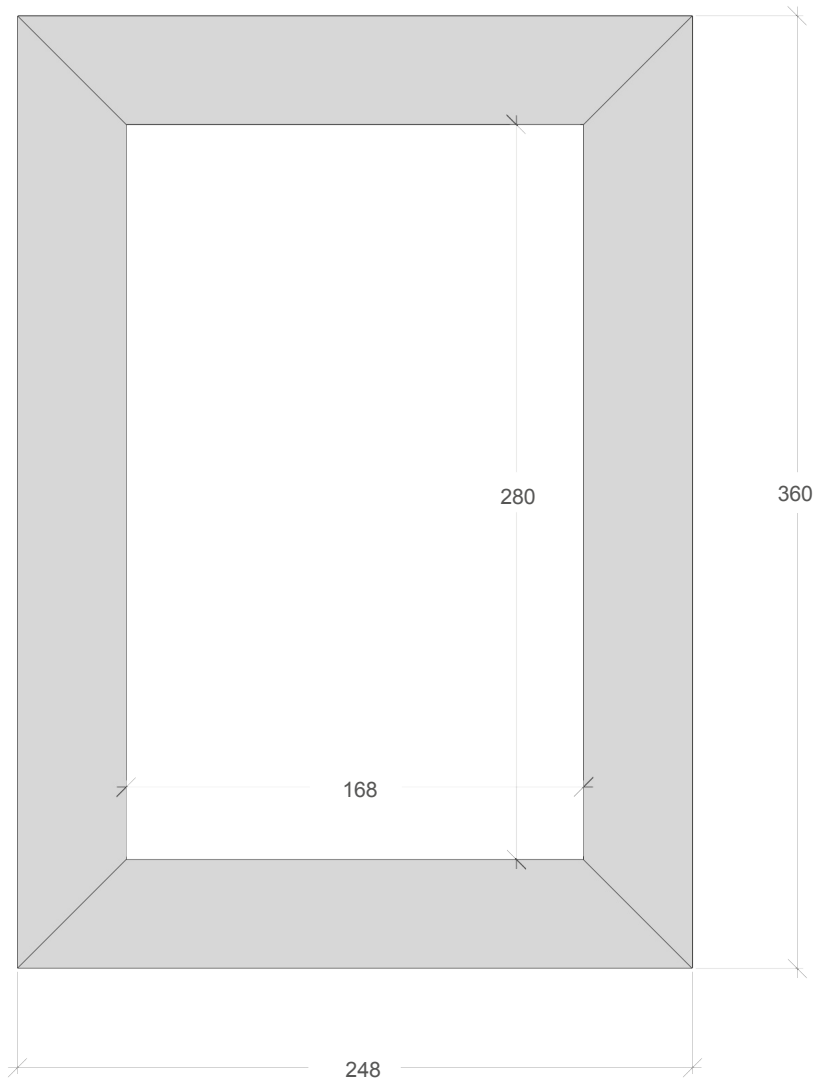

3. Door dimensions. Air vent plate

L-profile 40 x 40 x 4 mm, plate 168 x 76 x 4 mm

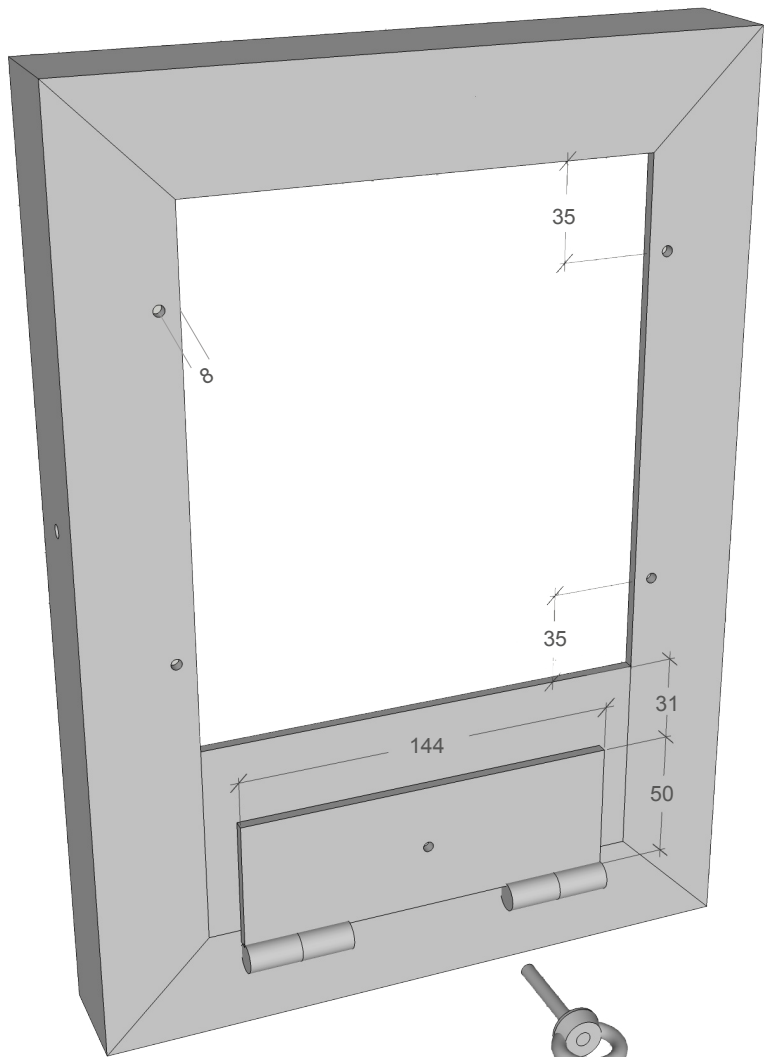

bolt with eye nut

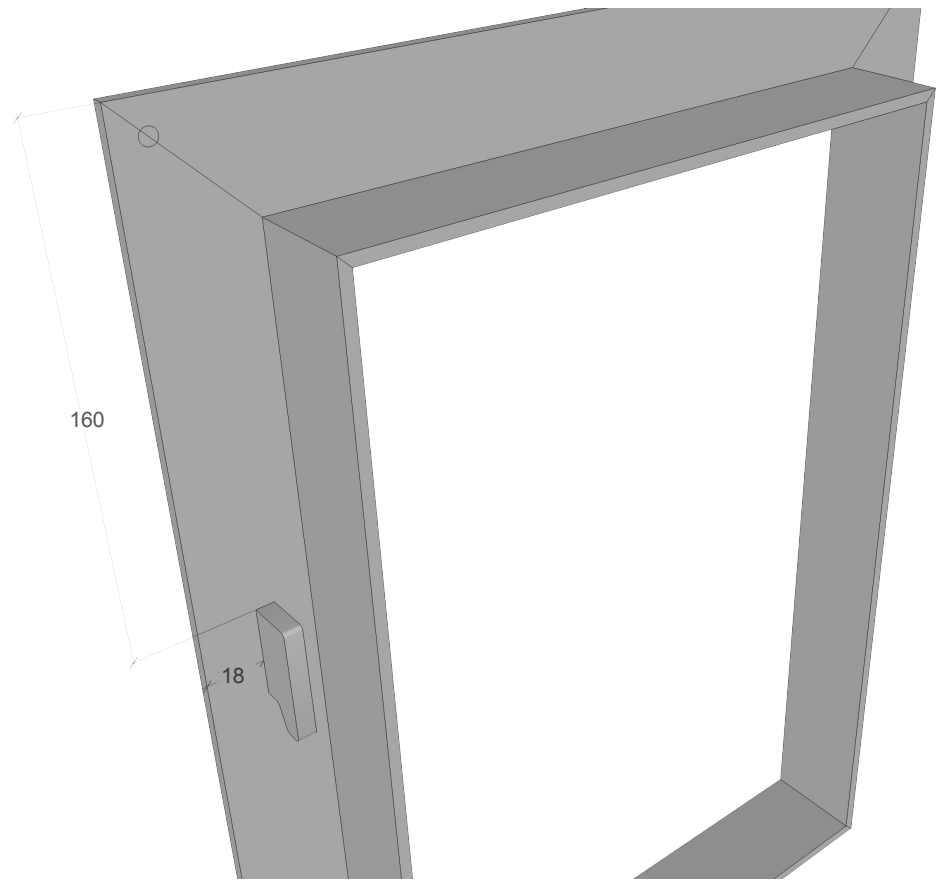

4. Door: shut-off valve. Frame: welding lip to frame

Valve 144 x 50 x 4 mm; lip 40 x 16 x 6 mm

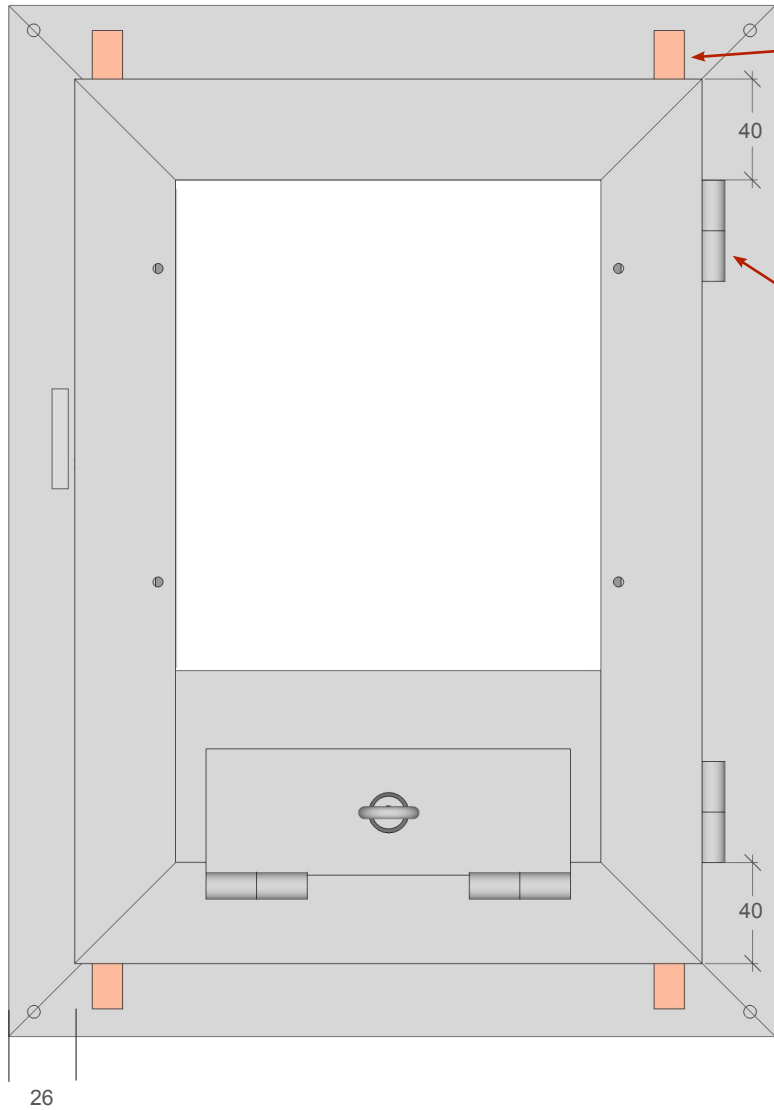

blocks 8 mm high

hinges ± 40 x 10 mm

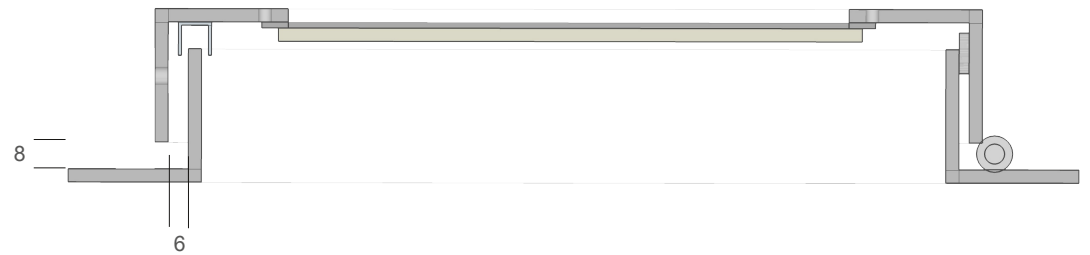

5. Frame and door: welding the hinges

The door "floats" 8 mm above the frame

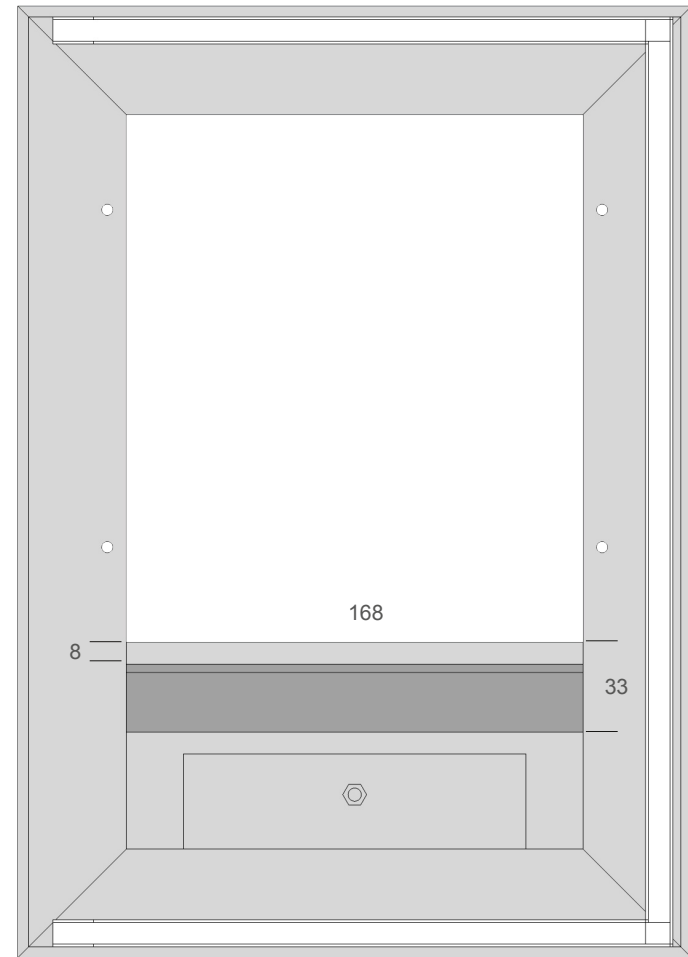
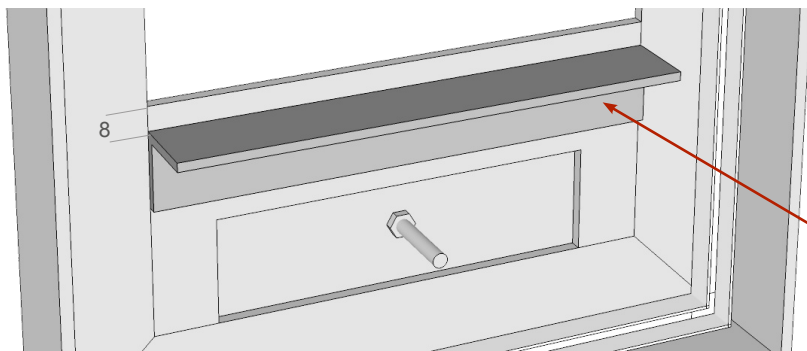
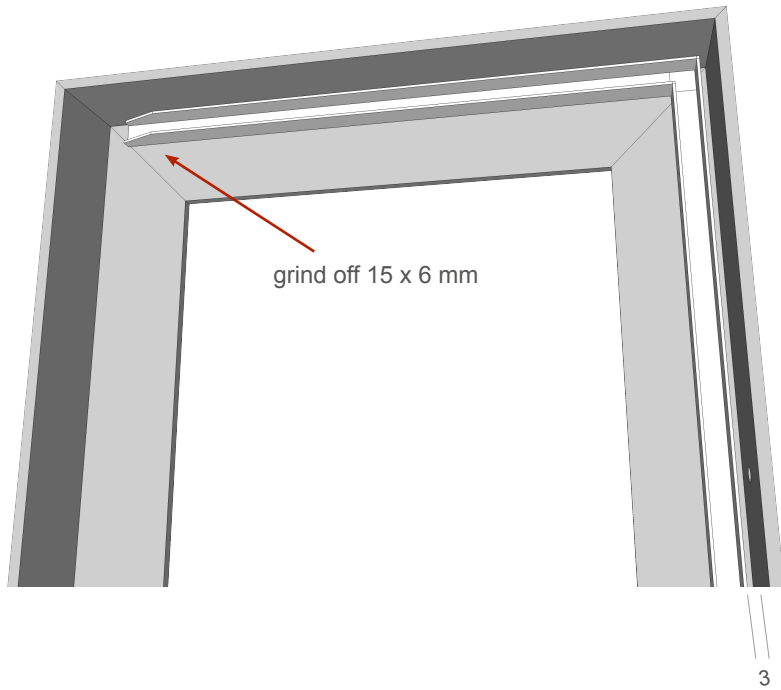

6. U-profile and L-profile inside the door

U-profile 10 x 10 x 1,5 mm, L-profile 25 x 25 x 3 mm

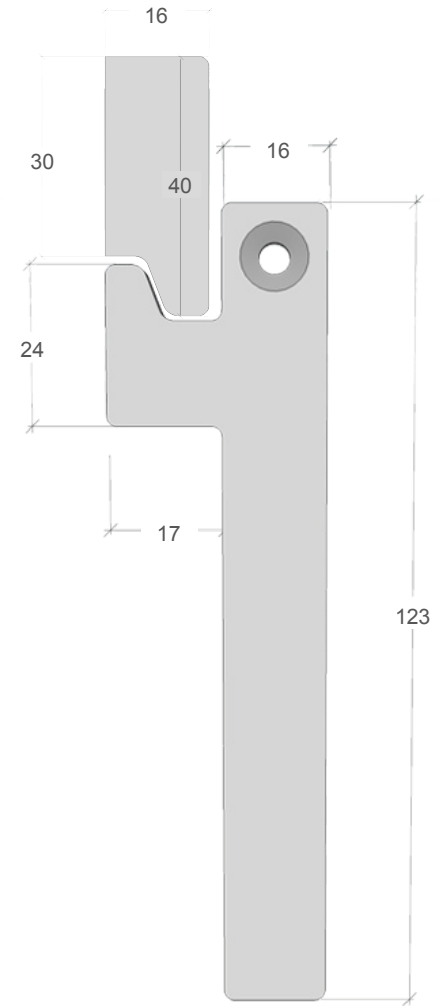
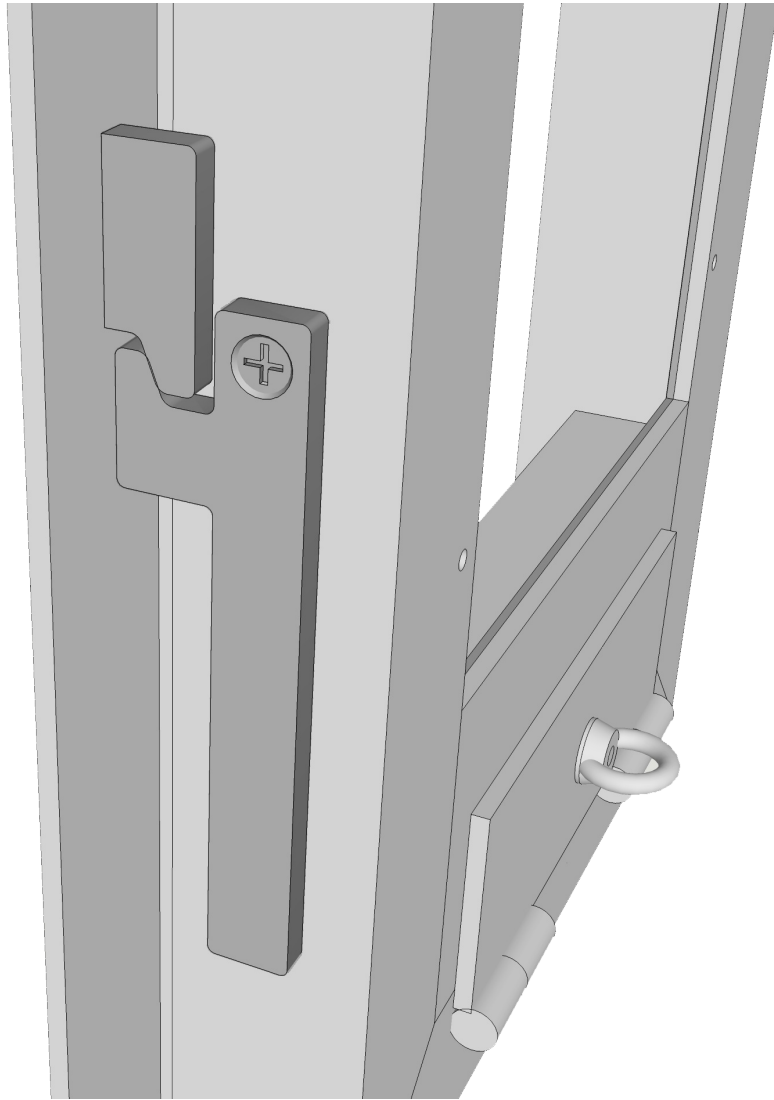

7. Lock

Steel plate 6 mm thick

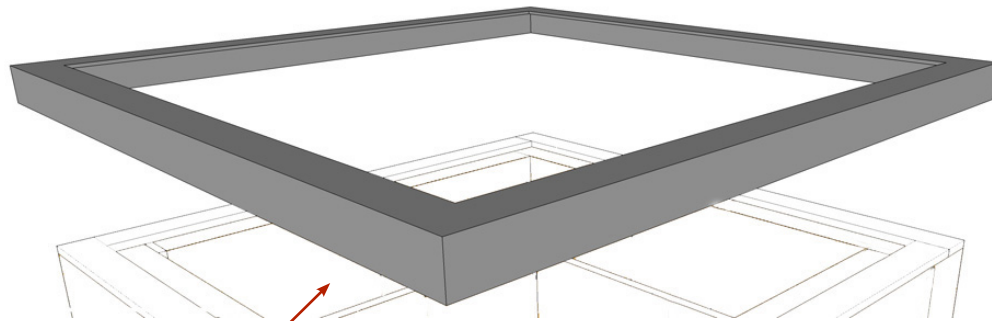
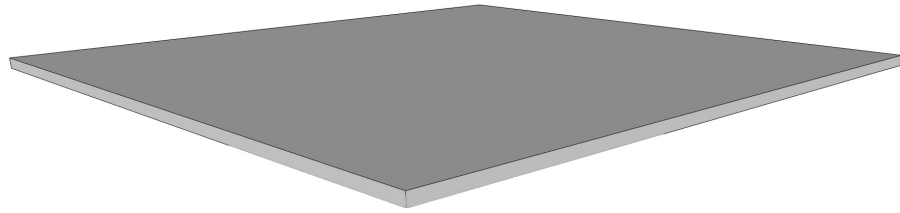

outside dimensions 608 x 608 mm
inside dimensions 558 x 558 mm

8. Top plate 550 x 550 x 6 mm

Steel top frame from L-profile 25 x 25 x 3 mm

Roquetinho

© 2024 roquetinho.eu. This pdf is part of the roquetinho building plan on roquetinho.eu. The building plan is available under the Creative Commons Attribution-ShareAlike 4.0 International license, see creativecommons.org. *Roquetinho* is an application of Peter van den Berg's Batch Box Rocket, see batchrocket.eu/en.